



**33760**

**UNDERCARRIAGE KIT**

**Dodge Ram 1500 4X4**

**2002 - 05**

**Installation Instructions**

**⚠ CAUTION**

Read this document before installing the snowplow.

**⚠ CAUTION**

See your BLIZZARD® outlet/Web site for specific vehicle application recommendations before installation. The Undercarriage Selection Guide has specific vehicle and snowplow requirements.

# SAFETY

## SAFETY DEFINITIONS

### ⚠ WARNING

Indicates a potentially hazardous situation that, if not avoided, could result in death or serious personal injury.

### ⚠ CAUTION

Indicates a potentially hazardous situation that, if not avoided, may result in minor or moderate injury. It may also be used to alert against unsafe practices.

**NOTE:** Indicates a situation or action that can lead to damage to your snowplow and vehicle or other property. Other useful information can also be described.

## Warning and Caution Label

### ⚠ WARNING

LOWER BLADE WHEN VEHICLE IS PARKED.  
DO NOT EXCEED GVWR OR GAWR INCLUDING BLADE AND BALLAST.  
REMOVE BLADE ASSEMBLY BEFORE PLACING VEHICLE ON HOIST.

### ⚠ CAUTION

READ OWNER'S MANUAL BEFORE OPERATING OR SERVICING SNOWPLOW.  
TRANSPORT SPEED SHOULD NOT EXCEED 45 MPH. FURTHER REDUCE SPEED UNDER ADVERSE TRAVEL CONDITIONS.  
PLOWING SPEED SHOULD NOT EXCEED 10 MPH.  
SEE YOUR SALES OUTLET/WEB SITE FOR SPECIFIC VEHICLE APPLICATION RECOMMENDATIONS.

59900

## WARNING/CAUTION & INSTRUCTION LABELS

Become familiar with and inform users about the warning and instruction labels on the back of the blade.

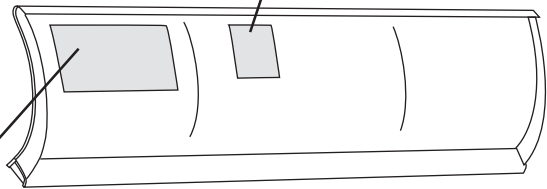

## Instruction Label

ATTACH	⚠ WARNING: Keep fingers away from snowplow and truck attachment points. POWER HITCH™ arm raises behind undercarriage pushbeam.	DETACH
<ol style="list-style-type: none"> <li>Slowly drive vehicle forward to engage pushbeam into A-frame.</li> <li>Turn power switch on light tower to center or "OFF" position.</li> <li>Plug in electrical harnesses.</li> <li>Pull A-frame latch pin and lower latch onto draw pin.</li> <li>Push UP and hold both power and arm/blade operation switches. Arm will engage pushbeam and pull snowplow towards vehicle.</li> <li>While pushing light tower toward vehicle, install both hitch pins and hair pin cotters. Hitch pin is fully engaged when stop is against A-frame.</li> <li>While holding UP power switch, push DOWN and hold arm/blade operation switch. Arm will disengage pushbeam to relieve tension on A-frame latch.</li> <li>Pull A-frame latch pin and raise latch away from draw pin. Lock latch in raised position.</li> <li>Push UP and hold both power and arm/blade operation switches to slightly raise blade. Raise kickstand until kickstand pin seats into upper hole on pivot beam.</li> <li>Turn power switch to down or "Plowing" position.</li> </ol>	<p>ATTACH – Steps 2, 5, 7, 9 &amp; 10 DETACH – Steps 2, 3 &amp; 5</p> <p>ATTACH – Steps 4, 7 &amp; 8</p> <p>ATTACH – Steps 1 &amp; 6 DETACH – Step 4</p> <p>Read Owner's Manual for Complete Instructions.</p>	<ol style="list-style-type: none"> <li>Lower snowplow onto ground with blade straight. Turn plow control in cab OFF.</li> <li>Turn power switch on light tower to center or "OFF" position.</li> <li>Push UP and hold both power and arm/blade operation switches to slightly raise blade. Lower kickstand until kickstand pin seats into lower hole on pivot beam.</li> <li>While pushing light tower toward vehicle, remove both hair pin cotters and hitch pins. Store pins.</li> <li>While holding UP power switch, push DOWN and hold arm/blade operation switch to fully lower arm.</li> <li>Unplug electrical harnesses.</li> </ol>

U.S. Patents 5,420,480; 5,638,618; 5,899,007; 6,178,669; 6,253,470; 6,276,076; 6,393,737; 6,408,549; 6,412,199; 6,442,877; 6,615,513; 7,134,227; RE 35,700;  
CAN Patents 2,060,425; 2,184,922; 2,229,783; 2,259,508; 2,358,145; 2,358,354; 2,466,195; and other patents pending.

50586

# SAFETY

## SAFETY PRECAUTIONS

Improper installation and operation could cause personal injury, and/or equipment and property damage. Read and understand labels and the Owner's Manual before installing, operating or making adjustments.

### **⚠ WARNING**

**Lower blade when vehicle is parked. Temperature changes could change hydraulic pressure, causing the blade to drop unexpectedly or damaging hydraulic components. Failure to do this could result in serious personal injury.**

### **⚠ WARNING**

**The driver shall keep bystanders clear of the blade when it is being raised, lowered or angled. Do not stand between the vehicle and the blade or within 8 feet of a moving blade. A moving or falling blade could cause personal injury.**

### **⚠ WARNING**

**Keep hands and feet clear of the blade and A-frame when mounting or dismounting the snowplow. Moving or falling assemblies could cause personal injury.**

### **⚠ WARNING**

**Do not exceed GVWR or GAWR including the blade and ballast. The rating label is found on the driver-side vehicle door cornerpost.**

### **⚠ WARNING**

**To prevent accidental movement of the blade, always turn the ON/OFF switch to OFF whenever the snowplow is not in use. The control indicator light will turn off.**

### **⚠ WARNING**

**Remove blade assembly before placing vehicle on hoist.**

### **⚠ CAUTION**

**Refer to the Undercarriage Selection Guide for minimum vehicle recommendations and ballast requirements.**

## PERSONAL SAFETY

- Remove ignition key and put the vehicle in park or in gear to prevent others from starting the vehicle during installation or service.
- Wear only snug-fitting clothing while working on your vehicle or snowplow.
- Do not wear jewelry or a necktie, and secure long hair.
- Wear safety goggles to protect your eyes from battery acid, gasoline, dirt and dust.
- Avoid touching hot surfaces such as the engine, radiator, hoses and exhaust pipes.
- Always have a fire extinguisher rated BC handy, for flammable liquids and electrical fires.

# SAFETY

---

## FIRE AND EXPLOSION

### WARNING

Gasoline is highly flammable and gasoline vapor is explosive. Never smoke while working on vehicle. Keep all open flames away from gasoline tank and lines. Wipe up any spilled gasoline immediately.

Be careful when using gasoline. Do not use gasoline to clean parts. Store only in approved containers away from sources of heat or flame.

## CELL PHONES

A driver's first responsibility is the safe operation of the vehicle. The most important thing you can do to prevent a crash is to avoid distractions and pay attention to the road. Wait until it is safe to operate Mobile Communication Equipment such as cell phones or two-way radios.

## VENTILATION

### WARNING

Vehicle exhaust contains lethal fumes. Breathing these fumes, even in low concentrations, can cause death. Never operate a vehicle in an enclosed area without venting exhaust to the outside.

# TORQUE SPECIFICATIONS

## TORQUE CHART

### ⚠ CAUTION

Read instructions before assembling. Fasteners should be finger tight until instructed to tighten according to the torque chart. Use standard methods and practices when attaching snowplow including proper personal protective safety equipment.



Grade Identification for J429–Grade 5 Bolt



Grade Identification for J429–Grade 8 Bolt

SAE J429 Grade 5 Torque Values				SAE J429 Grade 8 Torque Values			
Nominal Thread Size	Clamp Loads (lb)	Tightening Torque		Nominal Thread Size	Clamp Loads (lb)	Tightening Torque	
		"Lubricated"	"Dry"			"Lubricated"	"Dry"
1/4-20	2,000	6 ft-lb	8 ft-lb	1/4-20	2,850	9 ft-lb	12 ft-lb
5/16-18	3,350	13 ft-lb	18 ft-lb	5/16-18	4,700	18 ft-lb	25 ft-lb
3/8-16	4,950	23 ft-lb	31 ft-lb	3/8-16	6,950	32 ft-lb	44 ft-lb
7/16-14	6,800	37 ft-lb	50 ft-lb	7/16-14	9,600	53 ft-lb	70 ft-lb
1/2-13	9,050	57 ft-lb	75 ft-lb	1/2-13	12,800	80 ft-lb	107 ft-lb
9/16-12	11,600	82 ft-lb	109 ft-lb	9/16-12	16,400	115 ft-lb	154 ft-lb
5/8-11	14,500	113 ft-lb	151 ft-lb	5/8-11	20,300	159 ft-lb	211 ft-lb
3/4-10	21,300	200 ft-lb	266 ft-lb	3/4-10	30,100	282 ft-lb	376 ft-lb
7/8-9	29,435	321 ft-lb	430 ft-lb	7/8-9	41,550	454 ft-lb	606 ft-lb
1-8	38,600	482 ft-lb	640 ft-lb	1-8	54,540	680 ft-lb	900 ft-lb



Grade Identification for Metric–Grade 8.8 Bolt



Grade Identification for Metric–Grade 10.9 Bolt

Metric Class 8.8 Torque Values				Metric Class 10.9 Torque Values			
Diameter (mm)	Clamp Loads (lb)	Tightening Torque		Diameter (mm)	Clamp Loads (lb)	Tightening Torque	
		"Lubricated"	"Dry"			"Lubricated"	"Dry"
5	1,389	3 ft-lb	5 ft-lb	5	1,987	5 ft-lb	7 ft-lb
6	1,965	6 ft-lb	8 ft-lb	6	2,812	8 ft-lb	11 ft-lb
7	2,826	10 ft-lb	13 ft-lb	7	4,044	14 ft-lb	19 ft-lb
8	3,579	14 ft-lb	19 ft-lb	8	5,121	20 ft-lb	27 ft-lb
10	5,672	28 ft-lb	37 ft-lb	10	8,116	40 ft-lb	53 ft-lb
12	8,243	49 ft-lb	65 ft-lb	12	11,796	70 ft-lb	92 ft-lb
14	11,246	77 ft-lb	103 ft-lb	14	16,092	111 ft-lb	148 ft-lb
16	15,882	125 ft-lb	167 ft-lb	16	21,970	173 ft-lb	231 ft-lb
18	19,423	172 ft-lb	229 ft-lb	18	26,868	238 ft-lb	317 ft-lb
20	24,784	244 ft-lb	325 ft-lb	20	34,284	338 ft-lb	450 ft-lb

# UNDERCARRIAGE INSTALLATION

## INSTALLATION INSTRUCTIONS

**NOTE: For easier assembly and installation, vehicle and all snowplow components should be on a smooth, level, hard surface, such as concrete.**

1. Remove bumper and brackets by unbolting at frame. Retain fasteners.
2. Install mount by holding front portion of mount in place using bolt assembly. Clamp rear portion of mount into position on truck frame.

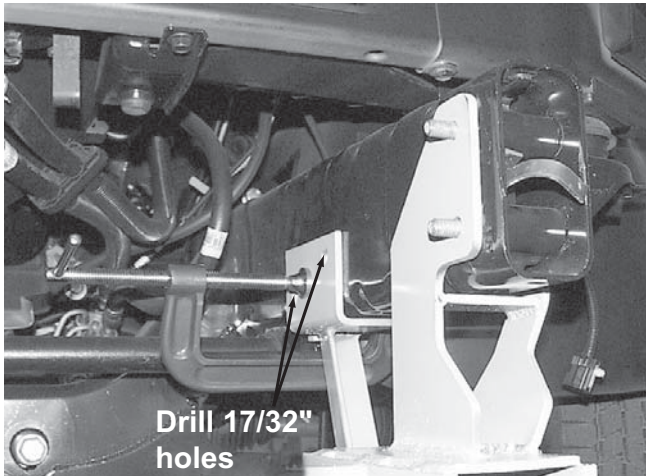

3. Use rear holes in mount as guides to drill two 17/32" diameter holes through the inner wall of the truck frame. Insert two 1/2" x 1-1/4" cap screws with handles past the opening in the front frame spacer, into truck frame and fasten with two locknuts. Hand tighten fasteners. Bend the handle on cap screws to prevent contact with the bumper bracket.
4. Install other mount as described in Steps 1–3.
5. Install the cross bar using four 1/2" x 1-1/2" cap screws and 1/2" locknuts. Hand tighten fasteners. Measure the distance between the U-brackets. The distance should be approximately 30-7/16" from center to center. Take a second measurement farther back on the mount to ensure they are parallel.

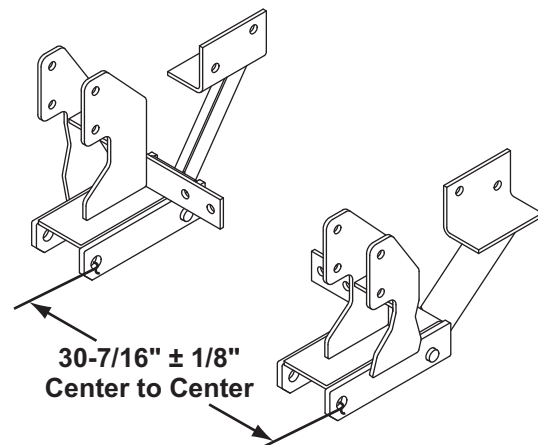

6. Remove air dam to allow sufficient clearance for mounts and mounting of blade assembly.
7. Remove bolt assembly from front of mount and reinstall bumper and brackets. Attach mount with bumper bolt assembly installed from the **outside** to the **inside**. Hand tighten locknuts.
8. Tighten all fasteners according to the torque chart.

# UNDERCARRIAGE INSTALLATION

9. With vehicle on level ground, measure from ground to center of the hole on U-bracket sideplate on mount.

The recommended height of the mount should be 14-1/4" or less from the center of the U-bracket hole to level ground. If the mount is higher than 14-1/4", the enclosed adapter plates need to be attached to the Mount Adapter. (The Mount Adapter comes packaged with the Blade Crate Assembly.)

If measured height is 14-1/4" or less, no height adjustment is needed.

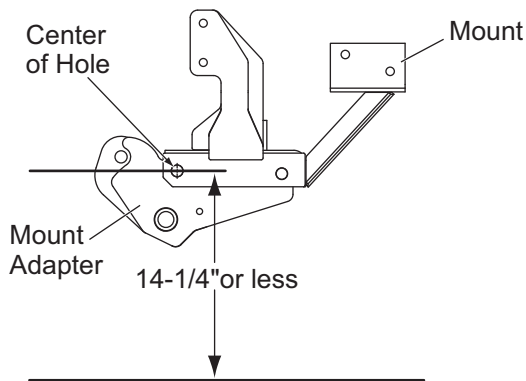

If measured height is 14-1/4" – 15-3/4", install the short height adjustment adapter plates as described.

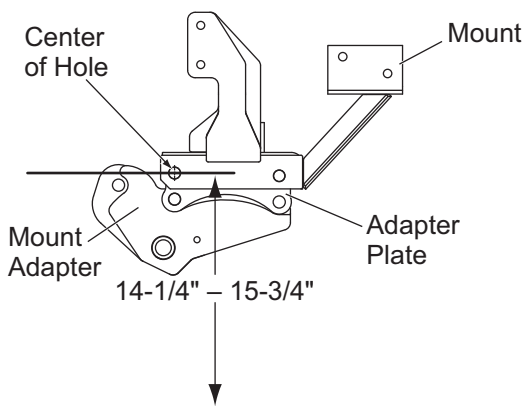

## MOUNT ADAPTER INSTALLATION

If adapter plates are required, install as follows:

1. Position the adapter plate against the driver's side portion of the mount adapter as shown. Insert a 3/4" x 2-3/4" cap screw through the lower front adapter plate hole and through the appropriate hole on the mount adapter. Secure with a locknut.

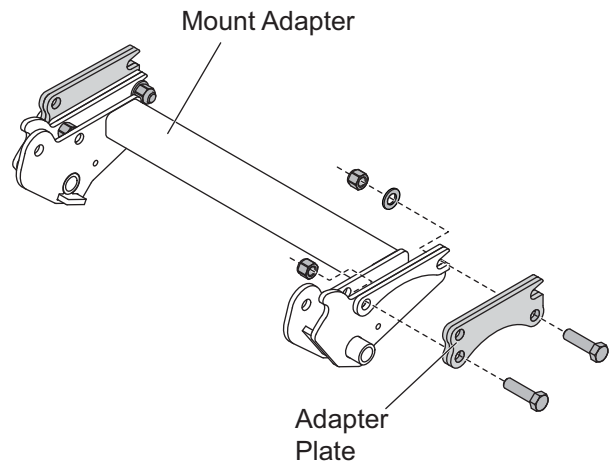

2. Insert a cap screw through the rear adapter plate hole, through the slot on the mount adapter and through a washer. Secure with a locknut.
3. Repeat for the passenger's side. Torque all four fasteners according to torque chart on page 4.

**NOTE: After five to ten hours of snowplow usage, retorque all undercarriage assembly fasteners.**



Blizzard  
P.O. Box 245038  
Milwaukee, WI 53224-9538  
[www.blizzardplows.com](http://www.blizzardplows.com)

 A DIVISION OF DOUGLAS DYNAMICS, L.L.C.

Blizzard reserves the right under its product improvement policy to change construction or design details and furnish equipment when so altered without reference to illustrations or specifications used. Blizzard or the vehicle manufacturer may require or recommend optional equipment for snow removal. Do not exceed vehicle ratings with a snowplow. Blizzard offers a limited warranty for all snowplows and accessories. See separately printed page for this important information. The following is a registered (®) trademark of Douglas Dynamics, L.L.C.: BLIZZARD®.

Printed in U.S.A.